

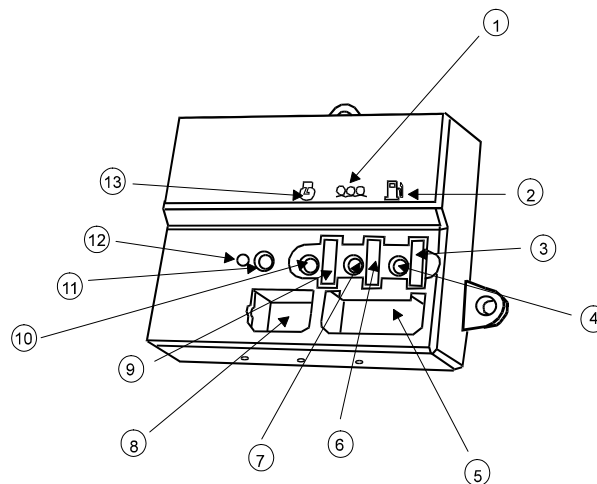

Engine Interface Module

The Engine Interface Module is a sealed, engine mounted module that provides switching relays for the Starter Motor Solenoid, Glow Plug and Fuel Solenoid. Each of these circuits is protected with individual automotive fuses mounted in the module. Individual LED's illuminate when each circuit is energized in addition these LED's greatly aid when fault finding.

This module is mounted on the engine with anti-vibration mounts and is easily connected to the engine via loom plugs. Use of the EIM means that heavy currents such as Fuel Solenoid power are isolated from the control panel thus enabling individual protection of each of the circuits.



<u>Item</u>	<u>Description</u>	<u>Item</u>	<u>Description</u>
1.	Glow Plug Symbol	8.	Secondary Socket
2.	Fuel Symbol	9.	Starter Solenoid Fuse
3.	Fuel Solenoid Fuse	10.	Starter LED
4.	Fuel LED	11.	Overspeed Set-up LED
5.	Main Connector Socket	12.	Overspeed Adjuster
6.	Glow Plug Fuse	13.	Starter Symbol
7.	Glow Plug LED		

Engine Interface Module

Functional Description

There are four versions of the Engine Interface Module available - the 12/24 volt EIM SR and the 12/24 volt EIM Plus.

The EIM SR is the basic level module that provides all the switching functionality; the EIM Plus provides the same functionality as the EIM SR plus the additional feature of Overspeed Sensing and an Overspeed Trip Adjuster. A magnetic pick-up on the engine flywheel housing provides the speed signal to the EIM Plus. When an overspeed situation is sensed, the EIM Plus signals the 2001, 4001 or 4001E generator set control panel to stop the engine. The Overspeed Trip Point can be easily set-up for 10% above the normal operating speed.

The overspeed feature on the EIM Plus, including the magnetic pickup is mandatory for all the Autostart control panels except the Access 4000 (2001, 4001 and 4001E).



Status Indication

LED's on the module correspond to the Starter Motor Solenoid supply, the Glow Plug supply (where used) and the Fuel Control Solenoid supply. Each illuminates to show that the indicated circuit is energized. A fourth LED (only operational on the EIM Plus) is used to set-up the Overspeed Trip Point.

Starter Motor Solenoid (EIM SR)

When the Keyswitch is turned to start, a relay in the module is energized providing power to the Starter Motor Solenoid. When the Keyswitch is released the relay is de-energized and disengages the starter motor.

Starter Motor Solenoid (EIM Plus)

During cranking the module receives a signal from the magnetic pick-up. When the signal rises above 1090 Hz, the starter motor is disengaged and the EIM Plus switches a zero volt signal to the generator set control panel to indicate that the engine is running.

Should the crank speed be less than 12 Hz, the module will only allow a crank of 0.6 seconds.

If the engine speed falls below 350 Hz (i.e. the engine has stopped) the EIM Plus will allow cranking only after a 5 second delay (lockout) which compliments the generator set control panel's 3 attempt crank.

Glow Plug (pre-heat)

When the relay is energized power is provided to the Glow Plug (where fitted).

Fuel Control Solenoid

The generator set control panel energizes a relay in the module that provides power to the Fuel Control Solenoid allowing fuel flow to the engine.

Overspeed Signal (EIM Plus only)

The EIM Plus monitors the speed signal from the magnetic pick-up. If the engine speed rises above a certain pre-settable value, the module sends a zero volt signal to the generator set control panel to activate the Overspeed Fault circuitry.

The Overspeed Set Point is factory set at 55Hz for 50Hz sets and 66Hz for 60Hz sets. This can be adjusted using the adjustment screw accessed through the hole beside the Overspeed Set-Up LED. While the engine is running at the rated speed (1500 rpm for 50Hz or 1800 rpm for 60Hz) the adjustment screw should be adjusted until the Overspeed Set-Up LED just goes out. This sets the overspeed value at 10% above the speed at which the generator set is operating.



Safety “Relay” Feature

The EIM SR and EIM Plus provide a safety check for any damaged contacts (i.e. welded contacts) using a “safety” relay. When the emergency stop pushbutton on the generator set control panel is pushed the EIM module automatically checks Fuel Control Solenoid and Starter Motor Solenoid to see if they are welded shut. A dimly lit LED on the module indicates the contacts are damaged and the module should be replaced.

Schematic Representation

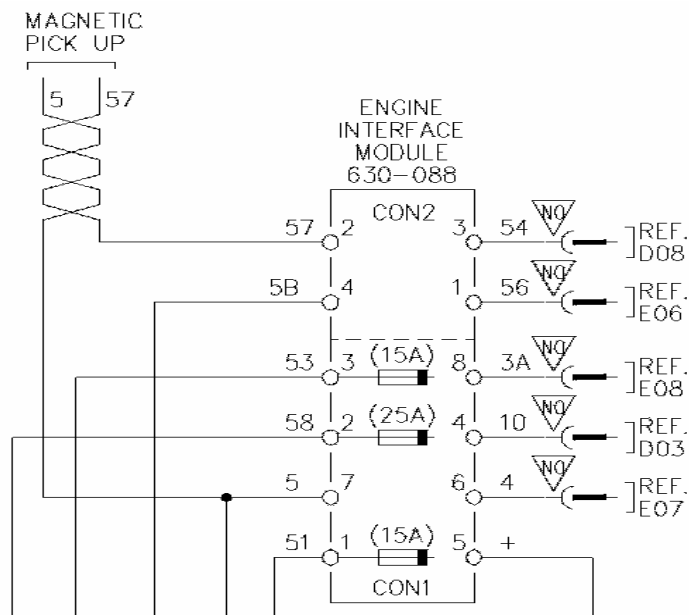

Connector	Pin	Wire	Function
Main	1	51	Output to Starting Solenoid
Main	2	58	Output to Glow Plug
Main	3	53	Output to Fuel Control Solenoid
Main	4	10	Glow Plug Input
Main	5	+	DC positive supply
Main	6	4	Starter Motor Input signal from control panel
Main	7	5	DC negative supply
Main	8	3A	Fuel Control input signal from control panel
Secondary	1	56	Overspeed signal output
Secondary	2	57	MPU signal input
Secondary	3	54	Engine Relay signal Output
Secondary	4	5B	Safety Relay DC negative